

# TYPE W

## Outline and Mounting Dimensions

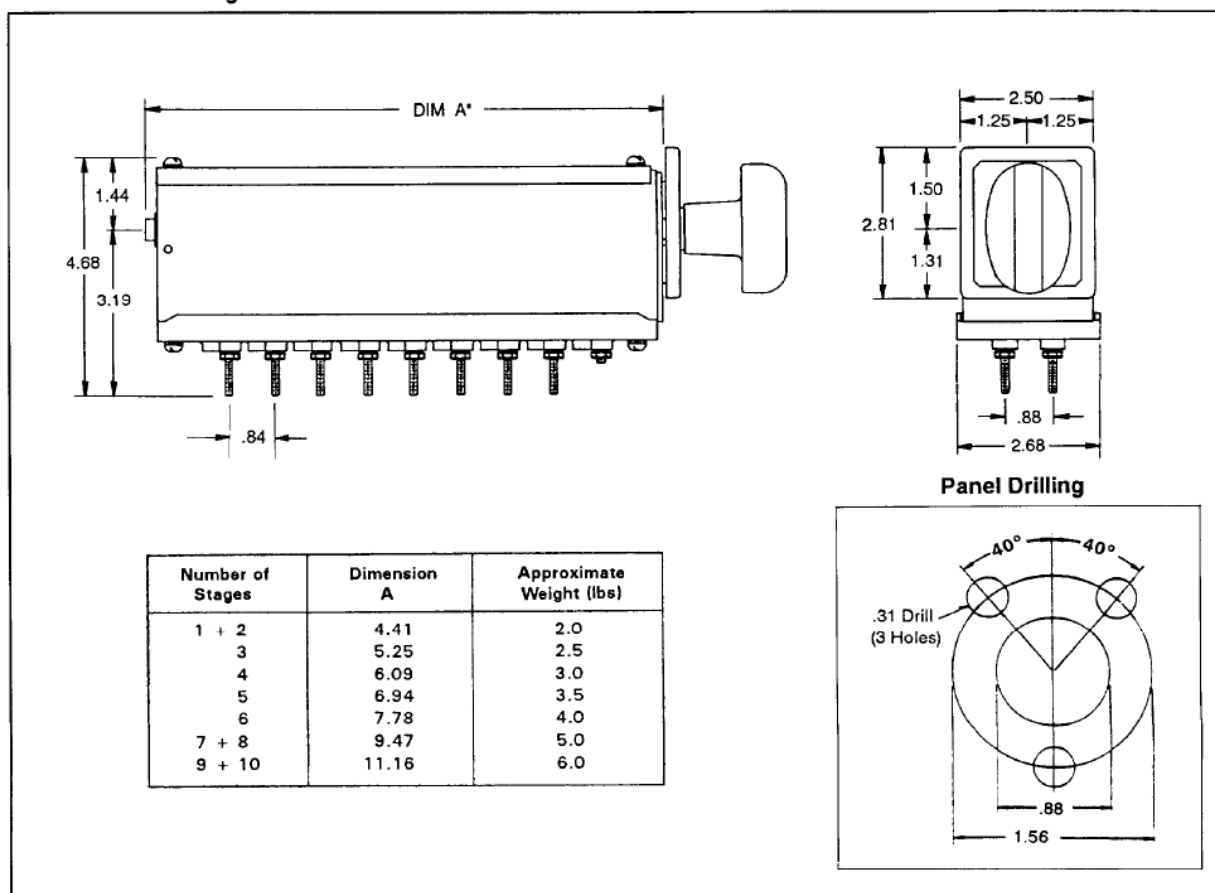

**HANDLES** Type W Switches are supplied with black molded handles. These handles are an integral part of the stop mechanism for position limiting of the switch. Therefore, when ordering handles it is important to specify the style number of the switch the handle is to be used on.

